

eXpress Version 7.3 — Join the MBSE Party!!

With the release of **eXpress** version 7.3, existing **eXpress** models can be used to perform Sneak Path Analysis—yet another addition to the growing list of tasks you can accomplish using a single set of models in **eXpress**.

Each time that DSI expands into a new discipline—testability analysis, diagnostic development, reliability assessment, fault tree analysis, prognostic evaluation, maintenance trade studies, sneak path analysis—the value of creating models in **eXpress** grows not proportionally, but exponentially.

eXpress data is applied during Fault Tree Analysis to determine the risk associated with sub-optimal diagnostics. Risk is usually not considered during diagnostic development and the Risk & Safety folks rarely, if ever, take actual diagnostics into account.

In addition to sneak paths, **eXpress** can identify areas where system failures, combined with sneak conditions, can result in potentially disastrous outcomes. Fault Tree Analysis—which evaluates the impact of different failure combinations—usually avoids having sneaky guests on its invite list.

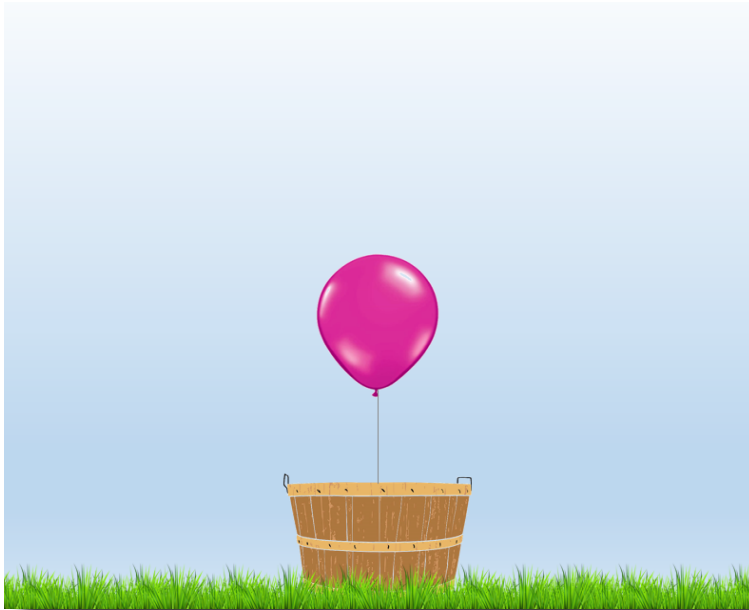

With single-purpose tools, engineering is a lonely endeavor.

Not only are you able to use **eXpress** models for multiple tasks in multiple disciplines, but you are also able to incorporate the information learned from one discipline into analyses that are normally treated as independent endeavors.

For instance, the Critical Failure Diagnosis chart in FMECA Plus helps analysts identify areas where system diagnostics are not sufficiently robust to support *operational* (as opposed to *logistic*) goals—an activity that is not a standard part of either testability or FMECA analysis.



Use **eXpress** and all your colleagues will want to join the party.

With all the excitement in the air about collaborative engineering, don't be satisfied with a field of single-purpose wallflowers. Invite **eXpress** to be the life of your MBSE party—you'll be surprised at the heights your team can reach.

Inside this Issue...

eXpress Version 7.3 — Join the MBSE Party!!	1
Sneak Path Analysis in eXpress	2-3
DSI Workbench Version 5.0	4
World Wide Representation	4

Keep In the Know

- **New Feature: Sneak Path Analysis Module**
- **Interoperability: TCP/IP Support in DSI Workbench**
- **Game Changer: Tablet-Based Diagnostics**
- **Coming up: Extensive Online Training**

Latest Software Versions

• eXpress	7.3	7/20
• Run-Time Authoring Tool	5.5.7	10/19
• DSI Workbench	5.0	9/20
• STAGE	Act II. Scene 3	10/16

Sneak Path Analysis Using eXpress

The new **eXpress** Sneak Path Analysis module allows sneak circuit analysis to be performed using the same hierarchical models that you've created for diagnostic and reliability engineering efforts in **eXpress**.

In addition to sneak path analysis, this module can also identify situations in which crosstalk or failures (alone, or in combination with other failures) result in undesired signal paths. It can then determine the probability that a critical failure path will occur (in a manner similar to the probabilities of failure that appear in a Fault Tree Analysis) and the likelihood that the failures leading up to a critical path will be prognosed, detected and/or diagnosed using the diagnostic strategies developed in **eXpress**.

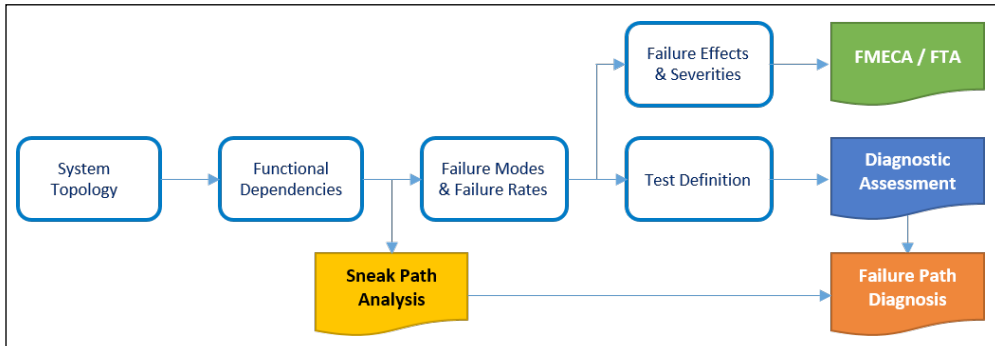

Sneak Path Analysis can be performed early in the modeling process—long before reliability and test data have been added. Sneak, failure and crosstalk paths can therefore be identified at a point when this knowledge can still be used to improve the design. Later, after diagnostics have been developed, you can determine the likelihood of failure paths occurring and see how well they can be prognosed and/or diagnosed.

The hub of the module is the Sneak Path Analysis dialog, which allows you to determine, examine and analyze sneak, crosstalk and/or failure paths within a hierarchical system modeled in **eXpress**.

In the example at right, the analysis uncovered no sneak paths. It did, however, identify a number of cases where one or more failures—analyzed in conjunction with possible sneak conditions (such as reverse signal flow or input-to-input shorts)—could result in a critical path that would not be identified as a sneak path. Because design activities that examine the impact of different failure combinations (such as FMECA & Fault Tree Analysis) do not take sneak conditions into account, this analysis can uncover high-risk areas of the design that might otherwise go undetected.

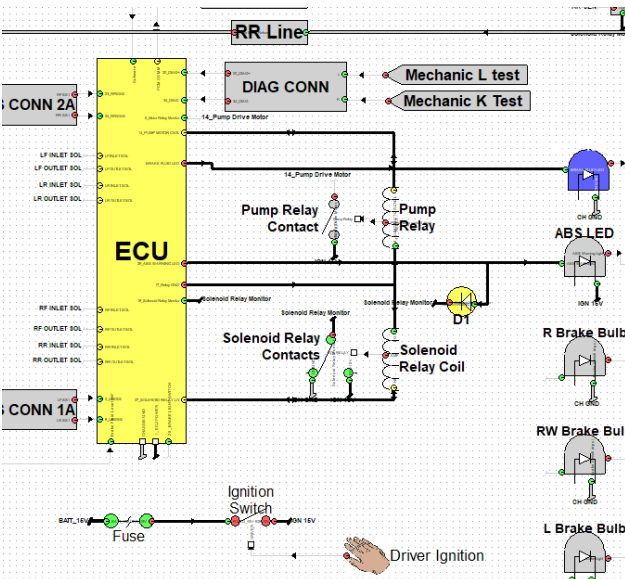
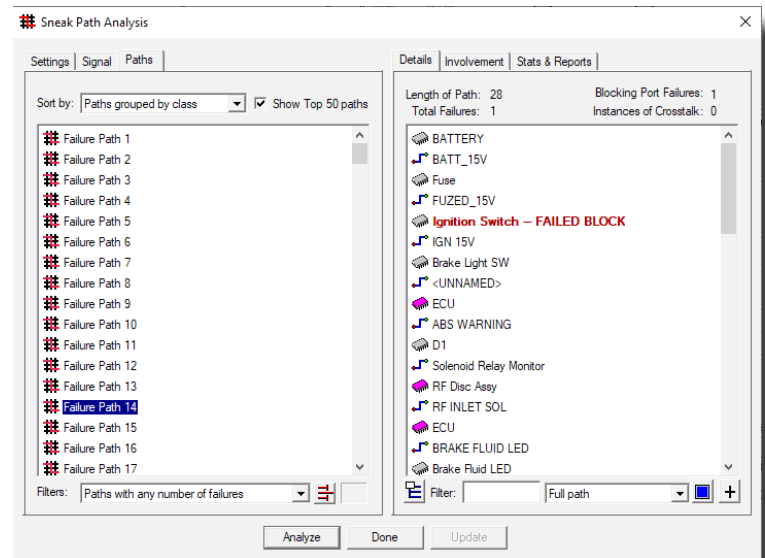

When a sneak, crosstalk or failure path is selected on this dialog, objects are color-coded in the main design window, allowing the analyst to easily review the path.

For instance, the analyst can easily identify by their colors those objects through which signals flow in reverse (yellow) and objects that must fail for a critical path to occur (red).

DSI Workbench Version 5.0

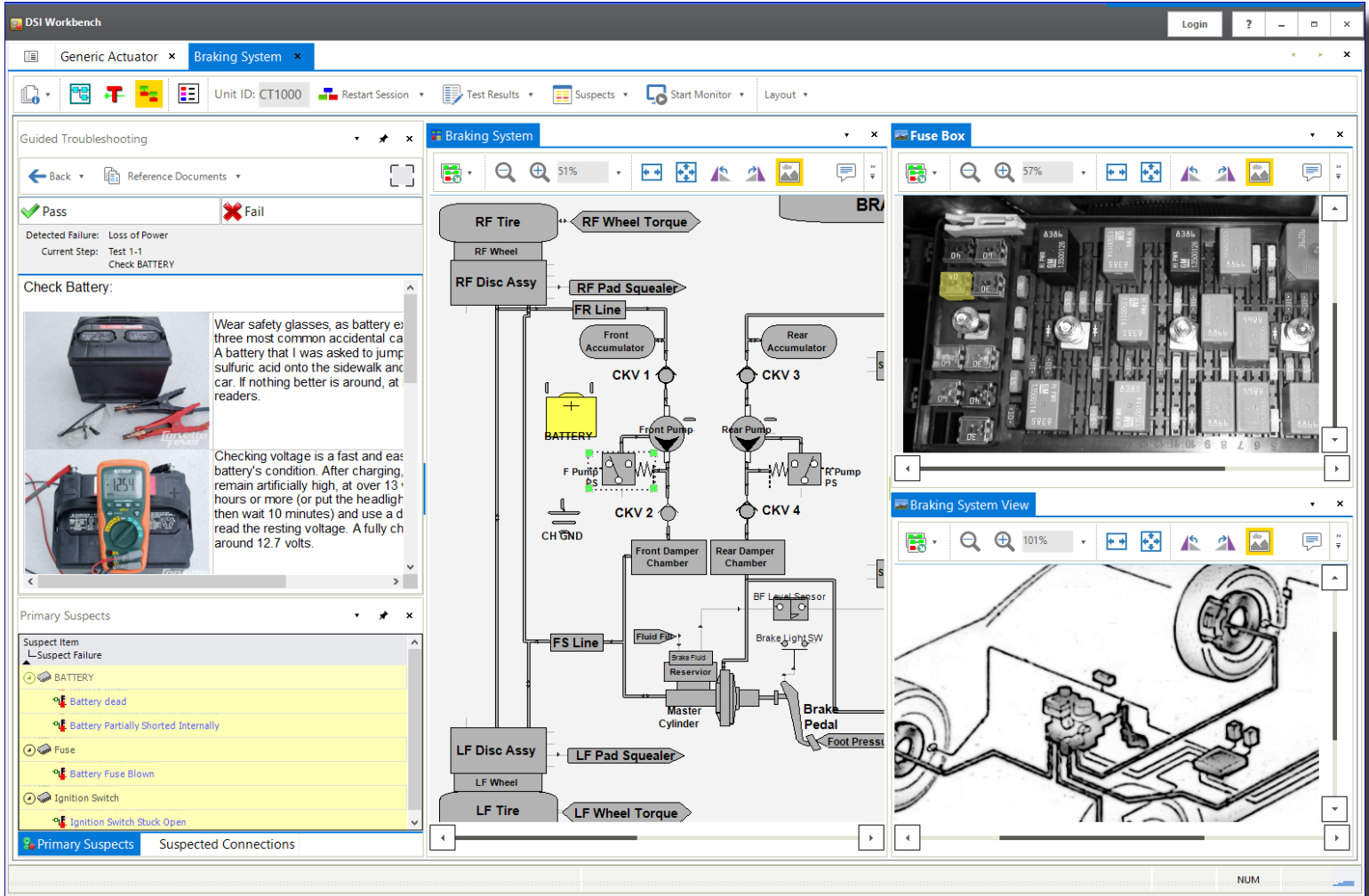

New in Version 5.0

DSI Workbench has a brand new GUI — That’s right, DSI Workbench has been overhauled with a new look to better support the latest run-time platforms (including computers with high-resolution 4K and touch displays).

Workbench’s new project management screen allows multiple diagnostic sessions to execute simultaneously. In addition to importing test results, users can now enter test measurements directly and Workbench will determine if the values indicate a Pass or Fail test result.

Messaging protocols using TCP/IP and windows message queues can be used to control communication to and from DSI Workbench in the test environment. Finally, item status colors can be selectively enabled or disabled for individual “views” using the color legend, allowing the technician to focus on exactly the components of interest.

- Support for high-resolution (4K) displays
- Redesigned GUI for touch panel displays
- Project management support facilitating the use of multiple diagnostics
- Ability for the user to enter measured values rather than Pass/Fail test results
- Master/Slave control of Workbench using TCP/IP messaging protocols
- View control using color legend



World Wide Representatives



United States

DSI International, Inc.
(714) 637-9325
info@dsiintl.com
www.dsiintl.com

United Kingdom

Sphera
Test Engineering Services
+44 (0)1202 868585
chris.gorringe@sphera.co.uk
www.sphera.com

France

Sphera
Test & Services
+33 (0)6 88 61 33 91
nicolas.chenneberg@sphera.com
www.sphera.com

South Korea

Realtimewave Co, Ltd
+82-2-572-9471/2
sales@realtimewave.com
www.realtimewave.com

China

MTCs
Systems Engineering Co. Ltd
+86-10-5881-6565
sales@mtcs.com.cn
www.mtcs.com.cn